

其余 ∇_{25}

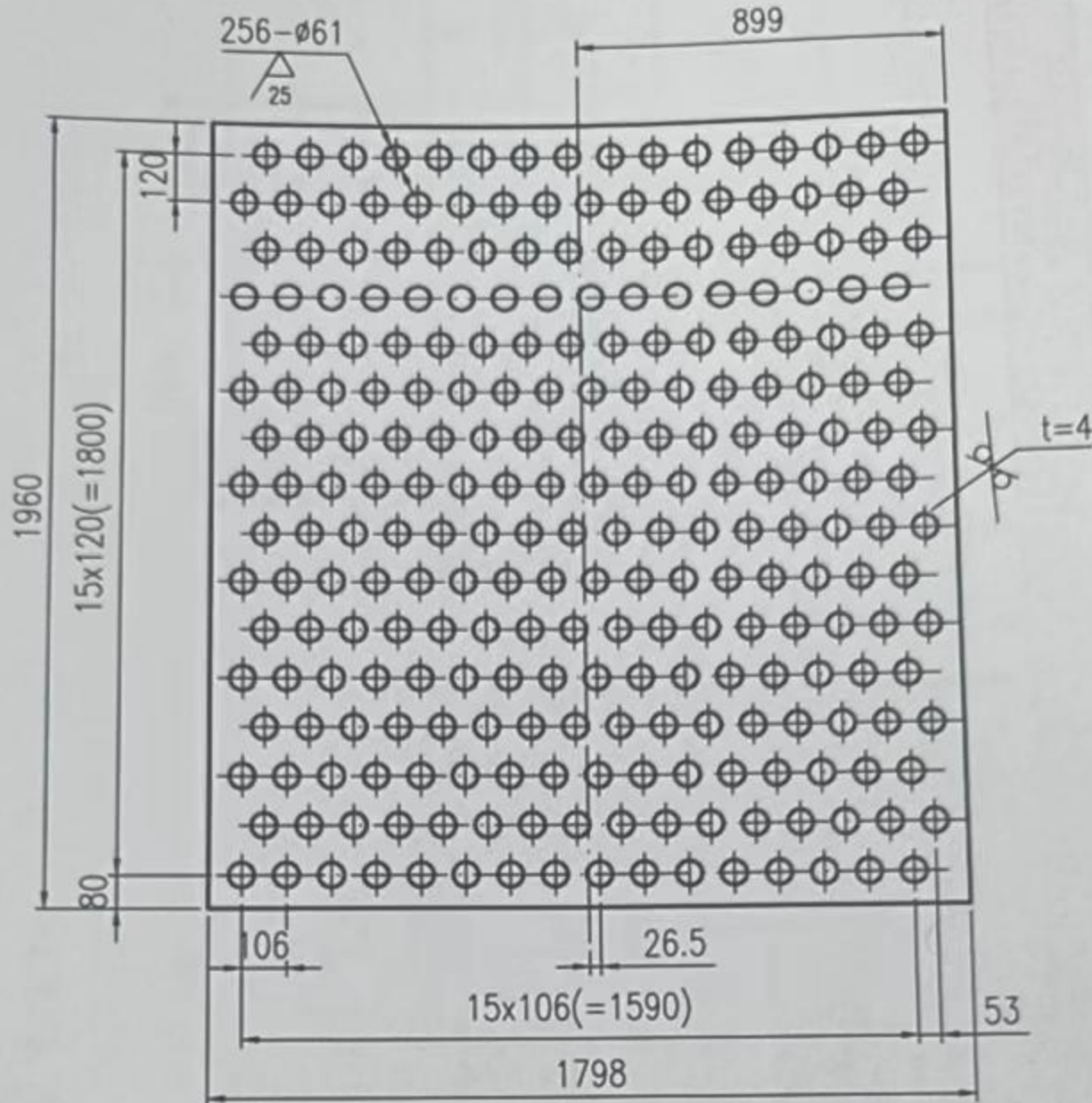

技术要求:

1. 钢板在加工前要求平直, 其不平度不大于1/1000.
2. 与前花板、中间花板和后花板一起配钻.
3. 花板去孔后理论净重91kg.

受控文件

					江苏索普赛瑞装备制造有限公司 SOPO CERE Equipment Manufacturing Co., Ltd.		
					S30408		钢板 t=4
MARK 标记	TOTAL NO. 处数	FILE NO. 更改文件号	SIGN 签名	DATE 日期	WEIGHT(kg) 重量	SCALE 比例	REV. 版次
DESIGN 设计	许大宇	2023.12.19	陈佩芸	2023.12.19	111.8	1:20	0
CHECK 校对	庄永平	2023.12.19	刘纪斌	2023.12.19	15SCG2309-1-1-7-1		
REVIEW 审核	张健	2023.12.19					
					TOTAL-PAGES 共 张	No.-PAGE 第 张	

本图纸及相关文件版权属于江苏索普赛瑞装备制造有限公司所有, 任何单位和个人未经江苏索普赛瑞装备制造有限公司书面许可, 不得以任何方式复制或扩散至第三方, 违者应负相应法律责任。
 THIS DRAWING AND RELEVANT DOCUMENT'S COPYRIGHT BELONGS TO SOPO CERE EQUIPMENT MANUFACTURING CO., LTD. THEY MAY NOT BE REPRODUCED OR DISCLOSED TO ANY THIRD PARTY IN ANY FORM WITHOUT THE PRIOR WRITTEN PERMISSION OF SOPO CERE EQUIPMENT MANUFACTURING CO., LTD. THE OFFENDERS SHALL BEAR THE CORRESPONDING LEGAL RESPONSIBILITY.

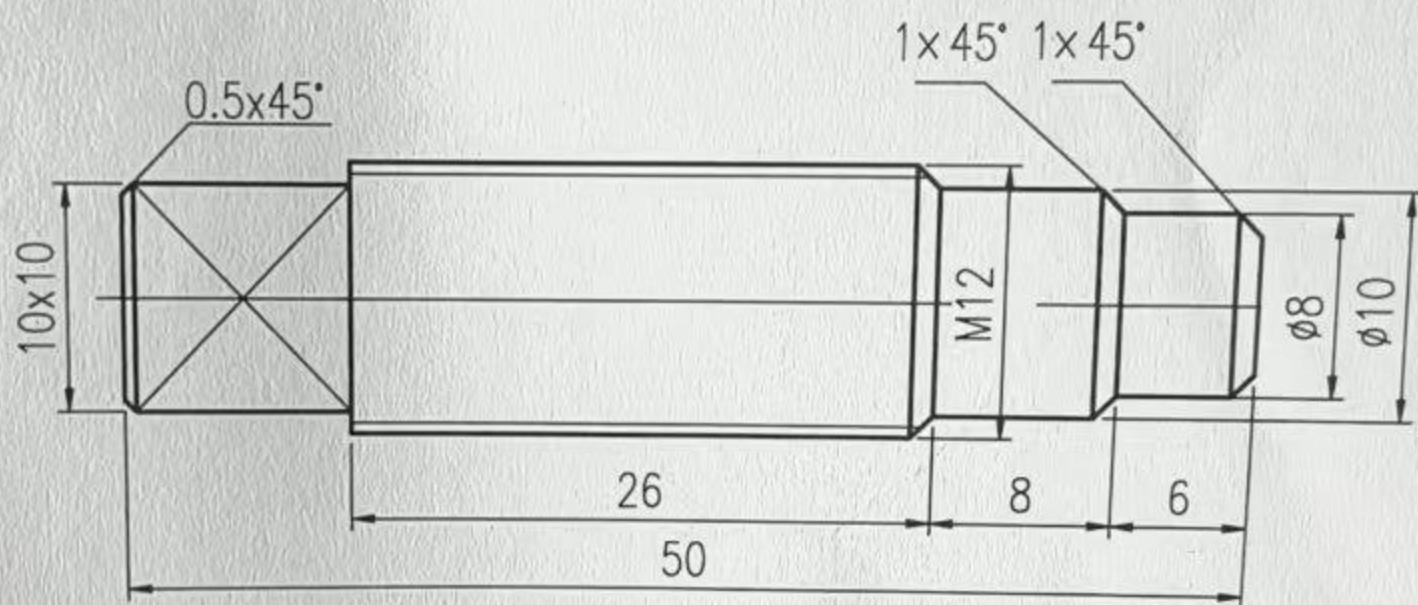

受控文件

					江苏索普赛瑞装备制造有限公司		
					SOPO CERE Equipment Manufacturing Co., Ltd.		
					12Cr1MoV		支承圆钢
MARK 标记	TOTAL NO. 处数	FILE NO. 更改文件号	SIGN 签名	DATE 日期	WEIGHT(kg) 重量	SCALE 比例	
DESIGN 设计	许大宇	2023..10.16	陈锦云	2023..10.16	0.04	2:1	0
CHECK 校对	庄永华	2023..10.16	刘元斌	2023..10.16	32SCG2307-1-11		
REVIEW 审核	张建	2023..10.16					
					TOTAL-PAGES 共 张	No.-PAGE 第 张	

本图纸及相关文件版权属于江苏索普赛瑞装备制造有限公司所有,任何单位和个人未经江苏索普赛瑞装备制造有限公司书面许可,不得以任何方式复制或扩散至第三方,违者应负相应法律责任。
THIS DRAWING AND RELEVANT DOCUMENT'S COPYRIGHT BELONGS TO SOPO CERE EQUIPMENT MANUFACTURING CO., LTD. THEY MAY NOT BE REPRODUCED OR DISCLOSED TO ANY THIRD PARTY IN ANY FORM WITHOUT THE PRIOR WRITTEN PERMISSION OF SOPO CERE EQUIPMENT MANUFACTURING CO., LTD. THE OFFENDERS SHALL BEAR THE CORRESPONDING LEGAL RESPONSIBILITY.